



Badger Meter

Industrial Meters

Oscillating Piston, Model OP Chemical & Sanitary,
Sizes 1/2", 1", 2"



CONTENTS

SCOPE OF THIS MANUAL	5
Description	5
INSTALLATION	6
Unpacking and Inspection.	6
Installation.	6
Dimension Examples	7
Performance Check	8
OPERATING INSTRUCTIONS	9
General Operating Instructions.	9
Shutdown Instructions	9
MAINTENANCE.	10
General	10
Preventive Maintenance	10
Calibration Check and Adjustments	10
Servicing	11
SPECIFICATIONS.	14

SCOPE OF THIS MANUAL

This manual contains information concerning the installation, operation and maintenance of Badger oscillating piston meters. To ensure proper performance of the meters covered, the instructions given in this manual should be thoroughly understood. Retain the manual in a readily accessible location for future reference.

Description

Badger oscillating piston meters are positive displacement type meters intended for use in fluid metering applications involving chemical solutions or food ingredients. The meters are available in a variety of size and configurations that cover a wide range of flow rates and special applications. The design of the meters incorporates a magnetic drive system that minimizes the number of parts in contact with the fluid being metered. A removable housing cover provides easy access to the internal components of a meter for cleaning and/or maintenance.

The basic components of an oscillating piston meter (see [Figure 1](#)) consists of a precision-machined housing, piston, magnet assembly, control roller and housing cover. In operation, the piston functions as the measuring element. As fluid flows through the meter, it causes the piston to oscillate within a measuring chamber in the meter housing. Each oscillation of the piston is proportional to a specific volume of fluid. The specific volume measured varies with the size of the meter. The larger the meter, the larger the volume of fluid measured for each oscillation of the piston. The circular oscillations of the piston are magnetically coupled through the wall of the measuring chamber to a follower magnet or an electromagnetic pickup which in turn operates a meter-mounted accessory such as a register or pulse transmitter.

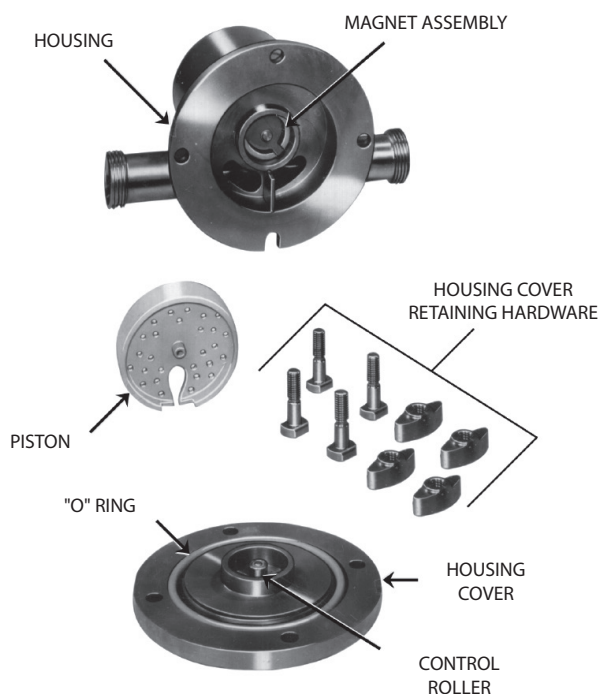

Figure 1: Meter Components

INSTALLATION

Unpacking and Inspection

To avoid damage in transit, Badger oscillating piston meters are shipped to the customer in a special shipping container. Upon receipt of the meter, perform the following unpacking and inspection procedures. If damage to the shipping container is evident upon receipt of the meter, request the carrier to be present when the meter is unpacked.

1. Carefully open the shipping container following any instructions that may be marked on the container. Remove all cushioning material surrounding the meter and carefully lift meter from container. Retain the container and all packing material for possible use in reshipment or storage.
2. Visually inspect the meter for any physical damage such as scratches, loose or broken parts, or any other sign of damage that may have occurred during shipment.

NOTE: If damage is found, request an inspection by the carrier's agent within 48 hours of delivery. Then file a claim with the carrier. A claim for equipment damaged in transit is the responsibility of the customer.

Installation

The procedure covering the installation of a standard oscillating piston meter are essentially the same regardless of the meter model being installed or the configuration involved. Before attempting the installation, read the instructions given in the following paragraphs to become familiar with the requirements and procedures involved. Any special instructions required for the installation and/or electrical connection of accessory equipment such as registers, pulse transmitters, remote batch controllers, etc., will be provided as a supplement to the manual.

Preliminary Considerations

Factors to consider before proceeding with installation:

1. Avoid locating the meter in close quarters. The area in which the meter is to be installed should provide adequate space to permit cleaning and maintenance.
2. Verify that the operating temperature range of the meter is compatible with the temperature range of the fluid or fluids to be metered.

CAUTION

THE METER MUST BE OPERATED WITHIN ITS RATED TEMPERATURE RANGE TO OBTAIN OPTIMUM ACCURACY AND PREVENT DAMAGE TO THE METER PISTON.

3. Ensure that the flow range of the meter agrees with the flow rate or rates to be used in metering the fluid.

CAUTION

THE LIFE OF THE METER MAY BE SERIOUSLY IMPAIRED IF OPERATED AT FLOW RATES ABOVE THOSE SPECIFIED.

4. If solid material is present in the fluid to be metered, it may be necessary to install a strainer in the facility piping ahead of the meter. In metering applications involving slurries, the finely divided, undissolved solids must be maintained as a suspension in the liquid. Oscillating piston meters are positive displacement type meters and may not operate properly with liquids containing solid particles unless the above precautions are observed.
5. In metering applications involving abrasive materials, slurries, or liquids that may leave a residue or buildup of deposits, a meter by-pass and flushing system should be incorporated into the facility piping installation to permit periodic clean-out of the meter. [Figure 2](#) illustrates a typical meter installation incorporating a bypass and flushing system.

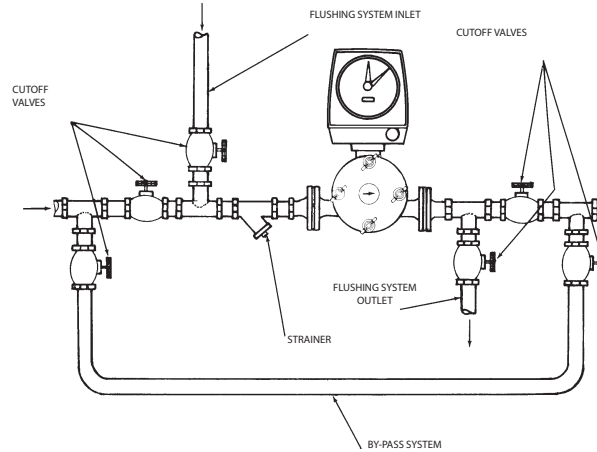

Figure 2: Installation Configuration

Dimension Examples

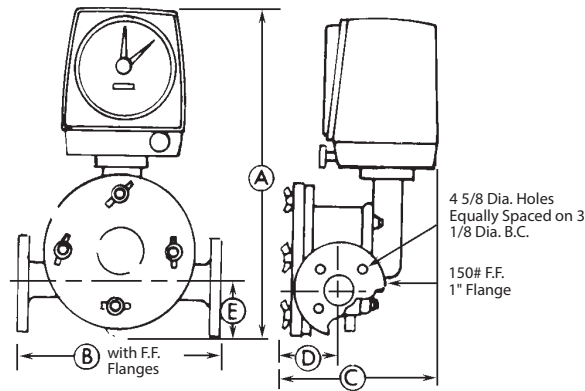
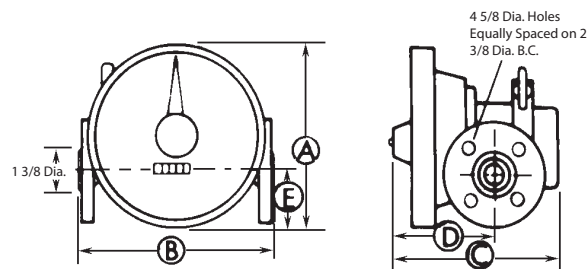

Figure 3: Dimensions example 1

Meter Size	A Height	B Laying Length	C Depth	D	E
1"	18-15/16"	11"	8-1/8"	3-7/8"	2-7/8"
2"	19-13/32"	12-5/8"	10-1/16"	5-5/8"	3"



Meter Size	A Height	B Laying Length	C Depth	D	E
1/2"	6-3/8"	6-3/4"	6-3/8"	4"	2-3/8"
1"	7-5/8"	11"	8"	3-5/8"	2-7/8"
2"	8-1/2"	12-5/8"	10-7/8"	5-1/2"	3"

Figure 4: Dimension example 2

Installing the Meter

The oscillating piston meters are designed for in-line installation. Examples of dimensions of the meter models, including laying lengths, are shown in "Figure 3". After reviewing the applicable dimension requirements, perform the following procedures:

1. Install appropriate mating connectors in pipeline. Provide proper gap length for meter. On meters with flanged ends, allow for gaskets at both inlet and outlet of meter.

NOTE: Always install meter in such a way that round cover is on a vertical plane, as shown on "Figure 2".

2. Install meter in pipeline making sure that flow arrow on housing cover is in proper relation to the direction of flow of the liquid.
3. Depending on meter size and line size, consideration may be given to placing a support under the meter to relieve any strain on the facility piping caused by meter weight.

Performance Check

Check the following to ensure the meter is properly installed and operational.

1. Check all piping connections to the meter for proper mating and firm connection.
2. Apply fluid pressure to the meter and check connections for possible leaks. Retighten connections as required.
3. Perform a functional test of the meter using the calibration check and adjustment procedures given in "Calibration Check and Adjustments" on page 10.

OPERATING INSTRUCTIONS

General Operating Instructions

The instructions for operating an oscillating piston meter depend on the meter-accessory combination and the type of flow control devices used in the facility piping. In general, the operation is either manually controlled or accessory controlled. Manual operation applies to metering applications employing hand-operated valves or other manually-activated, flow-regulating devices that are not functionally controlled by a meter-accessory device. Accessory controlled operation is used in metering applications involving meter-accessories that provide a signal output to activate and/or deactivate a valve or other type of flow control device.

CAUTION

REGARDLESS OF THE OPERATING PROCEDURE USED, THE VALVES OR DEVICES CONTROLLING THE FLUID FLOW THROUGH THE METER MUST ALWAYS BE OPENED AND CLOSED SLOWLY TO PREVENT SHOCK LOADS THAT MAY DAMAGE THE PISTON.

Manual Operation

Instructions are limited to the following start and stop procedures. The procedures are intended for use in simple metering applications where the flow of fluid through the meter is controlled by hand-operated valves located in the facility piping upstream and downstream of the meter.

1. Slowly open the upstream valve to apply fluid to the meter.
2. Slowly open the downstream valve to initiate metering.
3. Adjust the downstream valve so the flow rate does not exceed the flow rate specification of the meter.

NOTE: On meters equipped with an accessory device providing a totalizing indicator, the flow rate can be checked by timing the number of gallons registered in one minute.

4. To stop metering, slowly close the downstream valve; then close the upstream valve.

Accessory Controlled Operation

The step-by-step operating procedures used in accessory controlled metering applications are dependent on the specific function of the accessory employed and its electrical interconnection with a flow control device or devices. See the accessory's User Manual for specific operating instructions.

Shutdown Instructions

If a meter is to be shut down for an extended period of time (particularly when the application involves the metering of slurries or abrasive solutions), its measuring chamber should be thoroughly flushed out to prevent the settling out of undissolved solids or the accumulation of corrosive deposits. See ["Preventive Maintenance" on page 10](#) for cleaning instructions.

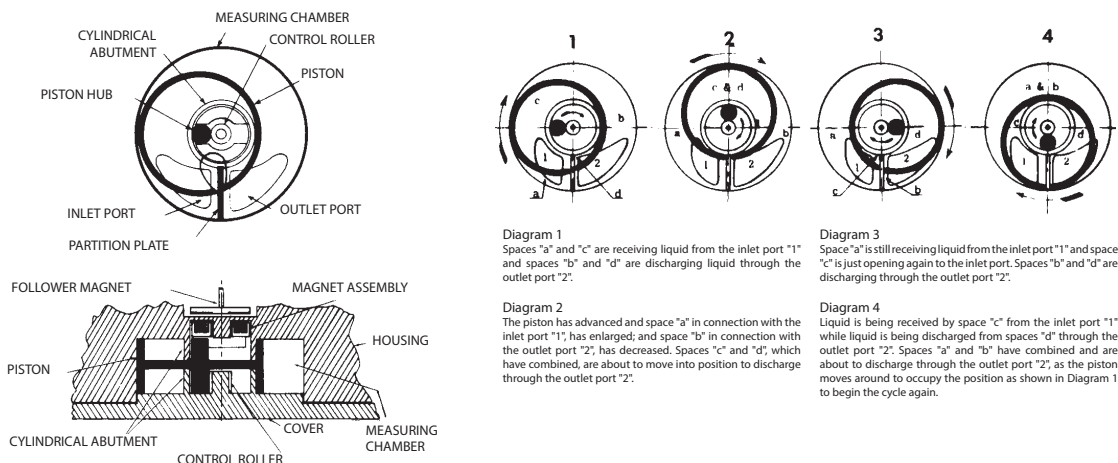

Figure 5: Shutdown Instructions

MAINTENANCE

General

This section contains information for servicing and maintaining of the meter. The information consists of preventive maintenance, calibration and adjustment and general servicing procedures. Instructions for ordering replaceable parts and assemblies are provided in an Illustrated Repair Parts Bulletin that is included with this manual. Any service and repair procedures applicable to a meter-mounted or free-standing accessory are provided in the bulletin or instruction manual covering the device.

Preventive Maintenance

The purpose of preventive maintenance is to ensure efficient operation and long life by detecting and correcting any defects before damage or meter failure occurs. Preventive maintenance consists of periodic inspection and cleaning procedures. The procedures should be performed at regular intervals and any defects discovered should be corrected before attempting further operation.

1. Visually inspect the meter and applicable accessory for loose connections, missing hardware, cracked or broken dial glass, damaged wiring or any other signs of wear or deterioration. Repair or replace parts as necessary.
2. Clean all dust, dirt or other foreign material from the exterior of the meter and accessory.
3. Fluid metering applications involving food ingredients require that Only manual cleaning (remove meter housing cover) can be used for sanitary OP meters.
4. Fluid metering applications involving chemical solutions can be cleaned manually or mechanically by a meter bypass and flush system.

If the facility piping arrangement includes a meter bypass and flushing system (see "Figure 2"), shut off fluid flow to the meter and flush interior of meter housing with clean water to remove any buildup of deposits or corrosion. If a bypass and flushing system is not included in the metering application, remove the meter housing cover and inspect the measuring chamber, piston and associated parts for any buildup of deposits or corrosion. Clean and flush parts with water or a suitable solvent that will not adversely affect the plastic components.

Calibration Check and Adjustments

All meters are accuracy tested with water at the factory using calibrated test equipment. However, because the meter can be used to measure a wide variety of liquids that may vary from water in viscosity, it is sometimes necessary to recalibrate a meter under actual operating conditions with the liquid being metered.

The following instructions are provided to assist in performing an on-site calibration check and adjustment.

Accuracy Test

1. Place a test tank of calibrated volume at the output of the meter.
2. Operate meter until test tank is filled to the appropriate calibrated level. Since meter accuracy varies somewhat with flow rate, make test run at the same flow rate used in actual operation.
3. Record quantity indicated on applicable meter accessory device.
4. Repeat run three times and average recorded indications.
5. Perform the following calculation to determine the percent of accuracy of the meter.

$$\frac{\text{Qty. Indicated on Accessory}}{\text{Actual Qty. in Test Tank}} \times 100 = \text{Meter Accuracy}$$

Example 1: $\frac{95 \text{ Gallons}}{100 \text{ Gallons}} \times 100 = 95\% \text{ Accuracy}$

In this example, the meter accessory is slow and must be speeded up by a calibration correction.

Example 2: $\frac{104 \text{ Gallons}}{100 \text{ Gallons}} \times 100 = 104\% \text{ Accuracy}$

In this example, the meter accessory is fast and must be slowed down by a calibration correction.

Change Gear Corrections

If the accuracy test of a meter-accessory combination that incorporates change gears indicates that adjustment is required, perform the following procedures.

1. See the Parts List for the location of the calibrating change gears.
2. Determine the number of teeth and the outside diameter of the existing change gears.

NOTE: The number of teeth and the outside diameter are stamped on each gear.

3. Submit an order for corrective change gears to the nearest Badger Meter Representative or the Industrial Division of Badger Meter, Inc. Provide the following information when ordering:
 - Meter Model, Size and Serial Number
 - Accessory Device
 - Unit of Measure or Pulse Rate/Unit of Measure
 - Number of Teeth and Diameter of Existing
 - Change Gears (Identify meter gear and register gear)
 - Percent of Accuracy of Meter

Change Gear Replacement

No special procedures are required when replacing change gears. However, take care to obtain full mesh of the gears. When installing a BRE, BRP or TR Register to a right-angle drive gear train, you can achieve proper gear mesh by observing or marking the position of the change gears on the respective spindles at the time of removal and making the replacement in the same position.

CAUTION

TAKE CARE NOT TO BEND THE SPINDLES WHEN INSTALLING THE GEARS OR REASSEMBLING A GEAR DRIVEN ACCESSORY TO THE METER.

Electronic Scaling Correction/Recalibration

If the test results indicate an adjustment is required where a meter-accessory combination incorporates an electronic calibrating feature, see the instruction manual for that accessory for the procedure to change scale factor.

Servicing

When periodic inspection or faulty operation of a meter indicates a need for servicing, refer to the following paragraphs for instructions covering the removal, inspection and reassembly of the replaceable parts comprising a meter. Use the exploded views given in the meter's Parts List as an aid in locating, identifying and removing parts and assemblies. If satisfactory repair cannot be made, contact the nearest Badger Meter Representative or the Industrial Division of Badger Meter, Inc.

Measuring Chamber

Instructions for removing, inspecting, and reassembling the parts contained within the measuring chamber are essentially the same, regardless of the size or type of meter involved.

1. Removal
 - a. Shut off the fluid flow to the meter.
 - b. Place a bucket or pan under the meter and relieve the fluid pressure in the meter by uniformly loosening the wing nuts on the cover (on 1/2" meters loosen the hinged, ring-clamp.) Fluid will spill out around the cover as pressure is relieved.
 - c. Remove the wing nuts and housing bolts (ring-clamp on 1/2" meters) and carefully remove the meter cover.
 - d. Remove the control roller from the pin in the center of the housing cover and the piston and magnet assembly from the measuring chamber.

2. Inspection

- a. Carefully examine the piston for warpage, cracks or other signs of wear and deterioration. Replace piston, if necessary.
- b. Check the magnet assembly and magnet assembly bushing (located on center pin inside chamber) for excessive wear and corrosion. Replace, if necessary.
- c. Check the control roller and control roller bushing. Replace, if necessary.
- d. Inspect the housing cover O-ring for wear and deterioration. Replace, if necessary.

3. Reassembly

- a. Place the magnet assembly on the bushing on the center pin inside the measuring chamber. Make sure the magnet assembly rotates freely.

NOTE: Magnet bushing must be snug on the housing pin. Replace the bushing, if necessary.

- b. Align the teardrop slot in the piston with the partition plate of the measuring chamber. Insert the piston into the chamber. Make sure the piston moves freely.
- c. Install the control roller over the bushing on the center pin in the housing cover. The control roller is easily positioned over the center pin when meter is in vertical position. Make sure control roller rotates freely.
- d. Align the holes in the cover with the mounting holes in the housing. Secure the cover in place with housing bolts and wing nuts (on 1/2" meter the cover is secured with a hinged, ring-clamp).

Drive Systems

Instructions for removing, inspecting and reassembling the accessory drive systems follow.

Magnetic Drive Adapter Assembly

1. Removal

- a. To remove the accessory from the castellated fitting on the adapter assembly, loosen the accessory seal screw and rotate the accessory 1/4 turn.
- b. Remove the three screws and washers securing the adapter assembly to the rear of the meter housing and carefully lift the adapter from the meter.

3. Inspection

- a. Check that the drive assembly operates freely when the follower magnet and spindle assembly at the front of the adapter is rotated.
- b. Check magnets, thrust bearing, ball races, and race retainer for signs of wear or corrosion. Clean and/or replace parts as necessary. If necessary, apply light coat of Lubriplate #905, Gredag #53A, or equivalent to thrust bearing.

3. Reassembly

- a. Secure the adapter assembly to the rear of the meter housing with the screws and washers removed in step 16.
- b. Install the accessory onto the adapter assembly and secure it in place with the seal screw.

Angle Drive Gear Train (1" and 2" Meters Only)

1. Removal
 - a. Remove the accessory device from the right-angle drive gear train.
 - b. Remove the three acorn nuts securing angle drive gear train to the rear of meter housing and carefully pull the gear train the from locating studs.
3. Inspection
 - a. Check that the gear train operates freely when the follower magnet is rotated.
 - b. Check the magnet-spindle assembly, thrust bearing, worm gear, drive spindle and bushings for wear and corrosion. Clean and/or replace parts as required. If necessary, apply a light coat of Lubriplate, Gredag #53A, or equivalent to the bearing and gears.
3. Reassembly
 - a. Align the mounting holes in the angle drive gear train with the locating studs at the rear of the meter housing and slide the gear train into place. Secure with acorn nuts.
 - b. Install the accessory on the angle drive the gear train. Make sure that the change gear on the output spindle of the gear train meshes properly with the change gear on the input spindle of the accessory.

Straight Drive Gear Train (1" and 2" Meters Only for MS-1 Transmitter)

1. Removal
 - a. Remove the three acorn nuts securing the gear train hood to the rear of the meter and remove the hood.
 - b. Loosen the two screws and clamps securing MS-1 pulse transmitter to the gear train and remove the transmitter.
 - c. Remove the straight drive gear train from the rear of the meter housing by removing the three #6-32 screws.
4. Inspection
 - a. Check that the gear train operates freely when thr follower magnet is rotated.
 - b. Check the magnet-spindle assembly, gears and bushing and plate assembly for signs of wear and/or corrosion. Clean or replace parts as required. If necessary, lubricate the gears with light coat of Lubriplate, Gredag #53A, or equivalent.
3. Reassembly
 - a. Secure the gear train assembly in place at the rear of meter housing with 6-32 screws retained from removal.
 - b. Install the MS-1 pulse transmitter and secure to the gear train assembly by the tightening clamp screw. Make sure that the change gear on the output spindle of the gear train meshes properly with the change gear on the input spindle of the transmitter.
 - c. Align the mounting holes in the gear train hood with the locating studs extending from the rear of the meter housing and slide the hood into place over the transmitter and gear train. Secure the hood in place with acorn nuts.

Recalibration

After repair or replacement of a meter part or assembly, perform a calibration check to ensure that the meter operates properly. See ["Calibration Check and Adjustments" on page 10.](#)

SPECIFICATIONS

	1/2"	1"	2"
Minimum Flow Rate, Q Minimum	1.5 gpm	5.5 gpm	25 gpm
Continuous Operating Maximum Rate	4 gpm	20 gpm	65 gpm
Short Duration Maximum Flow, Q Maximum Continuous operation is acceptable at these rates, but accelerated wear of the piston and/or bushings may occur.	6 gpm	30 gpm	100 gpm
Standard Flange Connections*, Chemical	150* psi ANSI 16.5	150 psi ANSI 16.5	150 psi ANSI 16.5
	1/2" Chemical meter can be ordered with 1" flanges for low flow applications on 1" lines. All sizes available with optional 300 psi flanges.		
Standard Connections, Sanitary Sanitary OP meters have 3A approval, Ultem piston required.	Tri-Clamp	Tri-Clamp	Tri-Clamp
Pressure Drop at Maximum Continuous Operating Flow (@ viscosity & specific gravity of water)	1.8 psi	6.3 psi	10.6 psi
Maximum Viscosity Limit	10,000 cps (flow range is decreased as viscosity increases). Contact factory for higher viscosities		
Maximum Operating Pressure	150 psi (300 psi optional)		
Maximum Operating Temperature	250 °F		
Minimum Operating Temperature** **Minimum temperature for stated accuracy.	40 °F		
Accuracy	± 0.5% over entire meter flow range		
Repeatability	± 0.2% or better under similar repeatable batch operations		

INTENTIONAL BLANK PAGE

Trademarks appearing in this document are the property of their respective entities. Due to continuous research, product improvements and enhancements, Badger Meter reserves the right to change product or system specifications without notice, except to the extent an outstanding contractual obligation exists.
© 2013 Badger Meter, Inc. All rights reserved.

www.badgermeter.com

The Americas | Badger Meter | 4545 West Brown Deer Rd | PO Box 245036 | Milwaukee, WI 53224-9536 | 800-876-3837 | 414-355-0400
México | Badger Meter de las Americas, S.A. de C.V. | Pedro Luis Ogazón N°32 | Esq. Angelina N°24 | Colonia Guadalupe Inn | CP 01050 | México, DF | México | +52-55-5662-0882
Europe, Middle East and Africa | Badger Meter Europa GmbH | Nurtinger Str 76 | 72639 Neuffen | Germany | +49-7025-9208-0
Czech Republic | Badger Meter Czech Republic s.r.o. | Maříkova 2082/26 | 621 00 Brno, Czech Republic | +420-5-41420411
Slovakia | Badger Meter Slovakia s.r.o. | Racianska 109/B | 831 02 Bratislava, Slovakia | +421-2-44 63 83 01
Asia Pacific | Badger Meter | 80 Marine Parade Rd | 21-04 Parkway Parade | Singapore 449269 | +65-63464836
China | Badger Meter | 7-1202 | 99 Hangzhong Road | Minhang District | Shanghai | China 201101 | +86-21-5763 5412

Legacy Document Number: IOM-020-12